

INSTALLATION AND OPERATION MANUAL

MODEL EV70\EV130\EV200\EV300

ENERGY RECOVERY VENTILATOR (ERV)



EV130 (door closed)



EV130 (door open)

⚠ WARNING

RISK OF FIRE, ELECTRIC SHOCK, OR INJURY.

OBSERVE ALL CODES AND THE FOLLOWING:

1. Before servicing or cleaning the unit, unplug the unit line cord. Make sure unit is not running before opening its door.
2. This installation manual shows the suggested installation method. Additional measures may be required by local codes and standards.
3. Installation work and electrical wiring must be done by qualified professional(s) in accordance with all applicable codes, standards and licensing requirements.
4. Any structural alterations necessary for installation must comply with all applicable building, health, and safety code requirements.
5. Connect this unit only to a 120VAC grounded receptacle protected by a 15 or 20 amp circuit breaker. Do not remove the unit's line cord.
6. Do not install unit or controls where they can be reached from a tub or shower.
7. This unit must be properly ducted to the outdoors.
8. Outside air inlet for this unit must be located away from sources of hazardous air such as auto exhausts.
9. Sufficient air is needed for proper combustion and exhausting of gases through the flue (chimney) of fuel burning equipment that might be installed in the area affected by this equipment. If this unit is exhausting air

- from a space in which chimney-vented fuel burning equipment is located, take steps to assure that combustion air supply is not affected. Follow the heating equipment manufacturer's requirements and the combustion air supply requirements of applicable codes and standards.
10. This unit is intended for general ventilating only. Do not use to exhaust hazardous or explosive materials and vapors. Do not connect this unit to range hoods, fume hoods or collection systems for toxics.
11. When cutting or drilling into wall or ceiling, do not damage electrical wiring and other hidden utilities.
12. Use the unit only in the manner intended by the manufacturer. If you have questions, contact the manufacturer.

⚠ CAUTION

1. To avoid motor bearing damage and noisy and/or unbalanced impellers, keep drywall spray, construction dust, etc., out of the unit.
2. Do not connect power to the units external control terminals: this will damage the unit. The external terminals are for use only with un-powered controls designed for low-voltage operation.

SYSTEM LAYOUT

Before you begin

Read all instructions before installing the unit. Also review supplemental instructions included with any controls that will be installed. Carefully unpack and inspect the unit for shipping damage. Open the access door and inspect inside the unit. Attach the four duct collars to the unit with the screws provided in the plastic small-parts bag.

Location of the Unit

Select a location so that:

- ◆ The fresh air intake vent from the outside is placed a minimum of ten feet from any other exhaust vent, and is at least 30" long.
- ◆ The two ducts to the outside are as short and straight as possible, for the best performance from the system. Shorter duct runs help assure that the system is balanced: the amount of air brought in is equal to the amount of air exhausted.
- ◆ The power cord reaches an electrical outlet.
- ◆ The door can be opened to allow cleaning the core and filters. **Provide at least 24" of clearance at front of unit for service access to the blowers, filters and energy**

exchange core.

- ◆ The exhaust outlet and fresh air inlet on the outside of the building should be at least ten feet apart to avoid cross-contamination. The exhaust duct should be about the same length as the fresh air duct.
- ◆ The exhaust outlet should not dump air into an enclosed space or into any other structure.
- ◆ Do not install the exhaust outlet and fresh air inlet through the roof or roof soffit. If these are the only available options call RenewAire technical support for help.

The preferred mounting location for the unit is on a concrete foundation wall because the foundation wall will isolate any blower vibration.

If a basement area is not available or practical, use other mechanical room space such as a closet, garage, storage, or accessible attic or crawl space.

NOTE: If you wish to install the unit in an attic or other unconditioned space, you must insulate all of the unit's ductwork that is located in the attic. Use at least R-6 insulation.

(A)

Separate Room Air Pick-up – Fresh Air to Furnace Return Air Trunkline

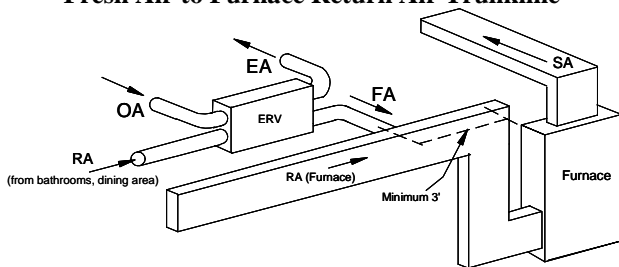

Note: ERV Blower may be operated separate from Furnace Blower

(B)

Separate Return Air and Fresh Air Supply

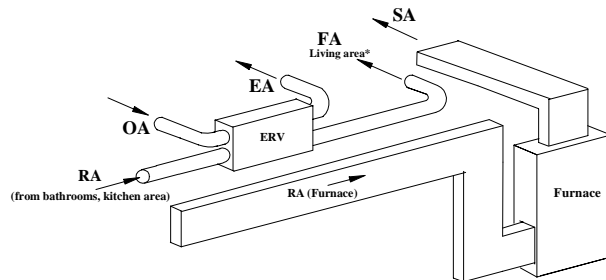

Note: ERV Blower may be operated separate from Furnace Blower
*Use caution to introduce FA at low velocity and where good mixing will occur to minimize discomfort from drafts

(C)

Furnace Return Air Back Into Return Air

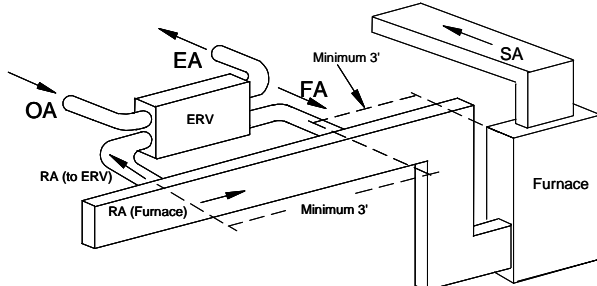

Note: The Furnace Blower must be operated any time the ERV is operated. Use furnace fan "on" continuous low speed or optional FM control to cycle furnace fan on with ERV

(D)

Furnace Return Air Into Furnace Supply Air

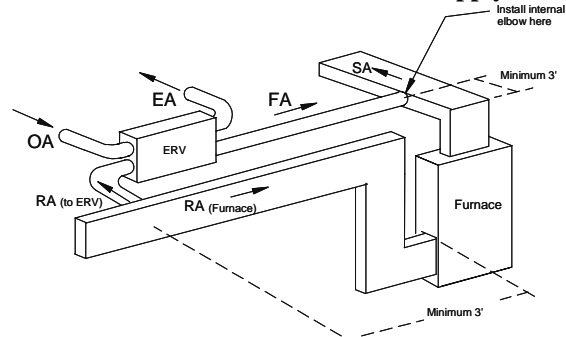

Note: ERV Blower may be operated separate from Furnace Blower

RA: Room Air
EA: Exhaust Air

OA: Outside Air
SA: Supply Air (furnace)

FA: Fresh Air

SYSTEM LAYOUT

Exhaust & Outside Air Ducts

The Exhaust Air Duct and the Outside Air Duct connect the unit to the outside. Flexible insulated duct is typically used. See Table under “Duct Sizes”, below

Inside Ductwork System

For houses without ducted heating or cooling systems – see Schematic (B):

In most houses one or two fresh air grilles in a central part of the house provide effective distribution of the fresh air into the home, particularly when the stale exhaust air is picked up at several points. Because the fresh air is usually somewhat cooler than the household air, the fresh air supply grilles should be located in a traffic area like a hallway or stairway rather than in a sitting area.

If you want to get fresh air into specific rooms with high occupancy, you can split up the fresh air supply.

For houses with forced-air heating and cooling systems – see Schematics (A), (C) and (D):

Most units are installed with the fresh air duct connected directly to a return duct for the main heating and cooling system. Be careful to connect the fresh air duct at least three feet from the return plenum to minimize suction from the furnace blower. A connection closer to the furnace may result in unbalanced flow and associated problems.

For installations that collect stale air from specific rooms in the home – for example, Schematics (A) and (B):

Locate stale air return grilles (RA) in rooms where moisture and odors are generated: bathrooms, the kitchen, and perhaps other areas where contaminants are generated such as in the home workshop. Return grilles in these other areas may be dampered so that they can be shut off when not in use. A central location such as a hallway is also acceptable but won't clear humidity and odors from baths and kitchens as rapidly.

Locate stale air return grilles (RA) near the ceiling on inside walls. Stale air returns are usually easiest to install in interior partitions. Put them in the ceiling if that is easier.

Stale Air Return Grill Sizes (8" round on EV300)	
Bathroom	4" X 10" or 6" X 10" - 40 to 60 sq. in.
Kitchen	6" X 10" or 60 sq. in.

CAUTION

DO NOT PLACE ANY STALE AIR RETURNS IN GARAGES.

Can an ERV be used to ventilate bathrooms?

A RenewAire ERV can be used as a central exhaust system in place of bathroom exhaust fans. Tie a grille in each bathroom

directly back to the ERV – see Schematic (A). A successful installation should provide at least 50 CFM of exhaust per moisture producing bathroom. When used for bathroom exhaust, the EV70 should be used for only one bathroom, the EV130 should be used for no more than two bathrooms, the EV200 for up to four bathrooms and the EV300 for up to six bathrooms. Install a control in each bathroom ventilated by the ERV (see Secondary Operating Controls, below).

For houses where radon is a concern:

The first line of defense against radon should always be techniques that prevent the entry of radon into the home, such as under-slab suction, vented perimeter drainage, and crack sealing. However, if moderate levels of radon continue to be present, it is important that the unit slightly pressurize the basement, *not de-pressurize the basement.*

Installation of this unit for radon mitigation is beyond the scope of this manual.

Consult a radon mitigation professional.

Duct Sizes

Duct Minimum Sizes and Type	
Exhaust Air & Outside Air (EA & OA)	6" round insulated duct (8" round for EV300) 8" round insulated duct may be used to maintain maximum airflow
Fresh Air & Stale Air (FA & RA)	6" round or 8" oval rigid un-insulated
All ducts from unit to house in unconditioned spaces like attics and crawl spaces MUST BE INSULATED.	

Controls

For an installation in which the ERV should run continuously in order to provide the required ventilation rate for the home, no controls are needed. However, in most installations, control over the unit operation is desired and this is best provided by a **Proportional Timer**.

A Dehumidistat is another option but works properly only during the heating season. If the ERV is used during the summer, a Proportional Timer should also be installed.

Proportional timers (PT or FM controls) may be located anywhere that is convenient, but Dehumidistats (DH24) must be located in the primary living area. A typical location for either control is next to the home's thermostat. Proportional timers operate the ERV to provide regular background ventilation of the home.

ERV installations that pull stale air from specific rooms, such as bathrooms, should have **Push-button (PB) Controls** in those rooms. The secondary operating controls allow the system to be turned on from various locations in the house.

INSTALLATION

Mounting the Unit

Unit may be installed in any orientation:

Orient the unit for the simplest duct layout and connections. Note however that the door is equipped with slide-off hinges. For the homeowner's convenience it is helpful to orient the unit so that the door does not drop off when it is unlatched.

Mounting the ERV on a concrete foundation wall:

Mount hanging bracket to the wall with appropriate concrete anchors. Use pre-cut foam tape from small parts bag. Remove backing and apply two pieces of foam tape equally spaced along the unit's mounting flange to be held by the hanging bracket. Apply the other two pieces of foam over two holes that will be used for fastening, on the other flange. The tape should be applied in a "U" shape to cushion both the front and back of the integral flanges. Lift unit and slide unit flange into the hanging bracket. Using metal flat washers, fasten flange opposite hanging bracket to structure. Safety screws should similarly be installed passing through the hanging bracket and flange. Make sure the screws, which you must supply, are properly selected for the loads and substrate involved.

Mounting the ERV to a stud wall:

Mount unit using supplied hanging bracket kit as described for mounting to concrete foundation wall. Note that the hole layout on the integral mounting flanges and the hanging bracket are spaced for 16" or 24" on-center framing patterns.

Suspending the ERV from floor joists or trusses:

The unit may be screwed directly to joists or trusses using the hanging bracket and integral flange. Mount as described for mounting to concrete foundation wall. Note that the hole layout on the hanging bracket is spaced for 16", 19.2" and 24" on-center layouts.

⚠ CAUTION

**RISK OF INJURY WHEN LIFTING UNIT AND INSTALLING IT OVERHEAD.
GET A HELPER AND WEAR EYE PROTECTION.**

Installing Outside Air and Exhaust Air Ducts:

Ducts connecting the unit to the outside must be well-insulated. Vapor barrier is required on both inside and outside of the insulation.

Band or tape inner duct liner to inner flange of appropriate collar. Drive a sheet metal screw through liner to secure duct spiral wire to collar. Straighten insulation, and slide outer duct jacket onto the outer flange of the duct collar. Secure with band or tape.

⚠ CAUTION

The vapor barrier should be continuous and sealed against air and moisture leakage! If not, condensation or ice may form in cold weather on the duct surface or in its insulation!

The inlets and outlets should be screened against insects and vermin and shielded from the weather to prevent the entry of rain or snow.

⚠ CAUTION

INSTALL FRESH AIR INLET AWAY FROM SOURCES OF CONTAMINANTS.

- ◆ Do not locate the fresh air inlet where vehicles may be serviced or left idling.
- ◆ The fresh air inlet should be at least ten feet away from any exhaust such as dryer vents, chimneys, furnace, and water heater exhausts or other sources of contamination or carbon monoxide.
- ◆ Never locate the fresh air inlet inside a structure.

Installing Return Air (RA) ducts:

All the stale air returns are connected by ducts to the unit. Generally, empty stud cavities are used for returns as is often done with cold air returns for the furnace, using standard duct boots to connect to six inch pipe at the bottom or top of the wall cavity. Always be sure to seal all joints with duct sealant or tape. Some local codes may require metal ducting all the way from the boots to the stale air grilles. Use rigid ducts to

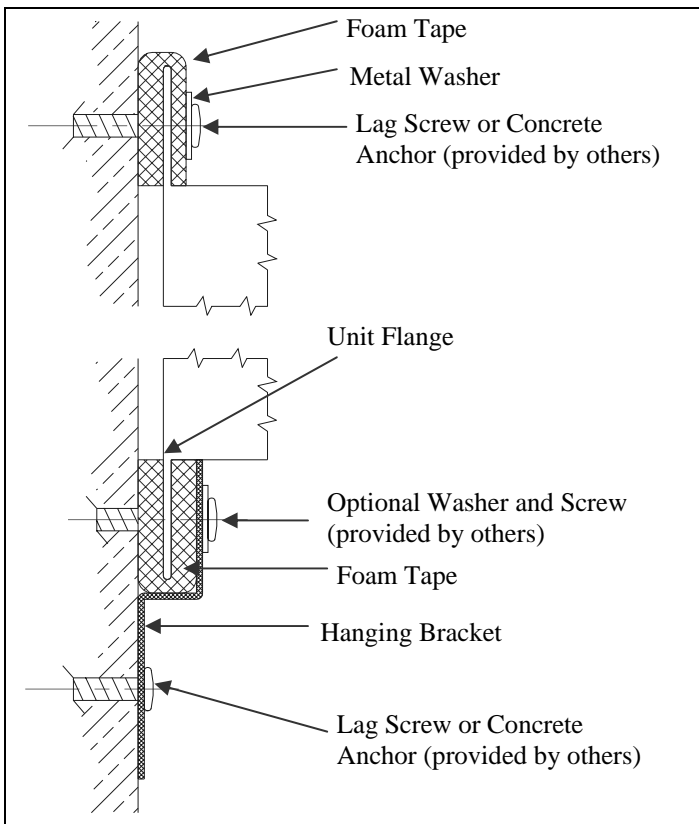

INSTALLATION

allow the air to move freely and easily through the ducts. See chart under System Layout to size your ductwork:

If duct runs are very long (over 25 feet of flex duct for 130 CFM or over 10 feet for 200 CFM each run) or have excessive bends or elbows or if maximum air flow rates are required, eight inch insulated flexible duct should be used. The outer flange of the duct collar can be used for both the inner and outer jacket of the flexible duct. Care must be taken to insure that the duct is securely fastened and sealed to the duct collar.

Do not use more flex duct than necessary!

Flex duct is much more resistant to airflow than rigid duct; longer runs of flex duct will reduce the ventilation performance of your system. Stretch flex duct and avoid sharp bends.

CAUTION

- ◆ Do not connect Dryers directly to the unit.
- ◆ Do not connect Range Hoods to the unit.

Installing Fresh Air (FA) ducts:

Use a five foot section of flexible insulated duct to connect the unit to the ducts at the port labeled *Fresh Air to the Inside*. This will cut noise transmitted from the unit. Stretch the flex duct tightly in order to maintain good airflow.

Installing Controls

WARNING

DANGER OF ELECTRICAL SHOCK WHEN SERVICING AN INSTALLED UNIT.

ALWAYS UNPLUG UNIT BEFORE CONNECTING OR SERVICING CONTROLS.

Optional controls:

RenewAire offers a variety of controls specifically designed to work with the EV70/130/200/300 products. These include: PT (a two wire proportional timer), FM (a six wire proportional timer that will interconnect with the furnace blower), and PB (point of use push button control). Other controls that throw an unpowered switch may also be used.

Typical control schematic:

Various wiring designs can be used to properly control the unit and meet safety and code concerns. Consult your electrician for an electrical design to meet your needs. The schematic below shows a typical control system: a PT proportional timer plus two PB push-button controls.

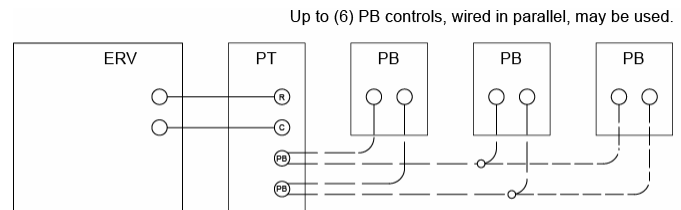

See installation manuals for the control(s) you select for wiring diagrams and specific instructions.

If NOT connecting controls to the ERV:

Make a jumper out of a short piece of wire. ERV will run full-time once its power cord is plugged in.

Starting Up the Unit

- ◆ Inspect your installation to be sure all duct work is correctly installed and sealed, that filters are in place, and controls (if any) are connected.
- ◆ Shut and latch the door to the unit.
- ◆ Plug unit into 115 VAC outlet. It may start immediately.
- ◆ Use control to turn on the unit. Check operation of the control(s).
- ◆ Check that the unit's safety interlock switch turns off the unit when the door is opened.

PRODUCT DATA

EV70/130/EV200/EV300

Energy Exchange System:	◆ Cross flow fixed-plate enthalpic energy exchange core: engineered, proprietary resin-media composite. Provides both sensible and latent heat transfer.
Certified Performance:	◆ See HVI Certified Ratings
Access Door:	◆ Front panel opens to provide access to filters, blowers, and heat exchanger. Snap latches and hinges provided for easy service.
Insulation:	◆ One inch foil-faced fiberglass throughout.
Mounting Options:	◆ Unit may be mounted to wall or floor joists using integral mounting flange with hanging bracket kit provided.
Blower/Motor:	◆ A single high efficiency PSC motor directly drives two large diameter centrifugal blowers for quiet operation.
Filters	◆ Cleanable polyester air filters for both exhaust and fresh air streams.
Defrost:	◆ Passive frost-free design under most residential conditions. Optional defrost accessory available for severe applications and climate zones.
Warranty:	◆ Ten year limited warranty on energy exchange core; two year limited warranty against defects in material and workmanship on all other components.

	EV70	EV130	EV200	EV300
Airflow Range:	◆ 40-85 CFM for each air stream.	50-140 CFM for each air stream.	100-200 CFM each air stream.	150-300 CFM each air stream.
Rated Airflow:	◆ 70 CFM for each air stream at 0.2 external static pressure (ESP).	130 CFM for each air stream at 0.2" external static pressure (ESP).	200 CFM for each air stream at 0.2" external static pressure (ESP).	300 CFM for each air stream at 0.4" external static pressure (ESP).
Dimension:	◆ 27 1/8" long x 18 1/4" wide x 10 5/8" deep (Not including duct collars).	28 3/4" wide x 20 1/8" high x 13" deep (not including duct collars).	28 3/4" wide x 20 1/8" high x 24" deep (Not including duct collars).	28 3/4" wide x 20 1/8" high x 24" deep (Not including duct collars).
Unit Weight:	◆ 44 lbs.	58 lbs.	80 lbs.	88 lbs.
Duct Connections:	◆ Insulating double collars with six-inch/eight-inch round connections for flexible or rigid duct work.	Insulating double collars with six-inch/eight-inch round connections for flexible or rigid duct work.	Insulating double collars with six-inch/eight-inch round connections for flexible or rigid duct work.	Insulating double collars with 8-inch oval connections for flexible or rigid duct work.
Electrical:	◆ Power: 0.1 HP, 120 Volt, 60 Cycle, single phase, 1.0 FLA, 94 watts at 70 CFM. Control: On-board 24 volt transformer and relay.	Power: 0.1 HP, 120 Volt, 60 Cycle, single phase, 1.3 FLA, 124 watts at 121 CFM. Control: On-board 24 volt transformer and relay.	Power: 0.1 HP, 120 Volt, 60 Cycle, single phase, 1.5 FLA, 157 watts at 181 CFM. Control: On-board 24 volt transformer and relay.	Power: 0.2 HP, 120 Volt, 60 Cycle, single phase, 3.3 amps, 313 watts at 300 CFM. Control: On-board 24 volt transformer and relay.

PRODUCT DATA

EV70

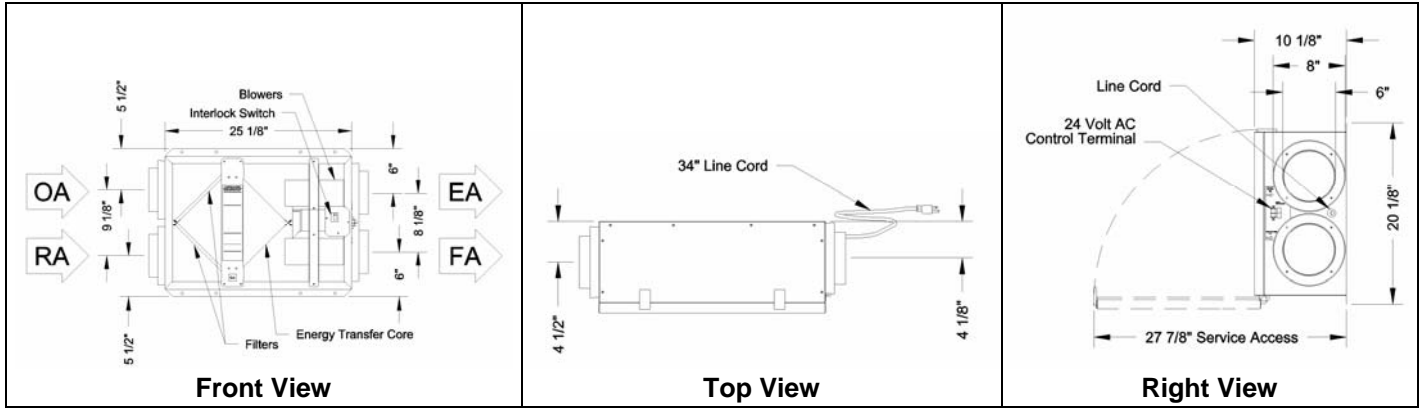

EV130

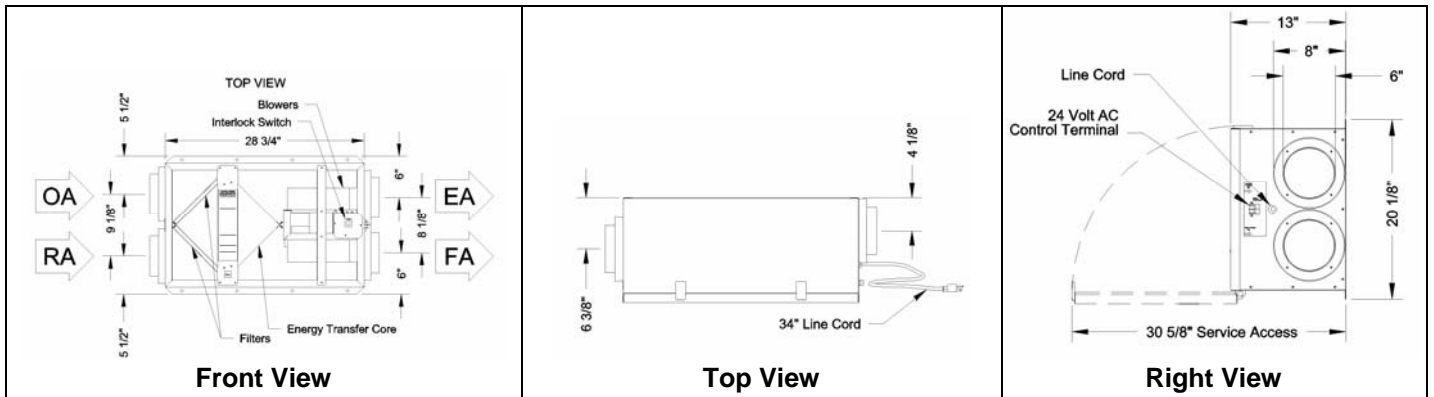

EV200

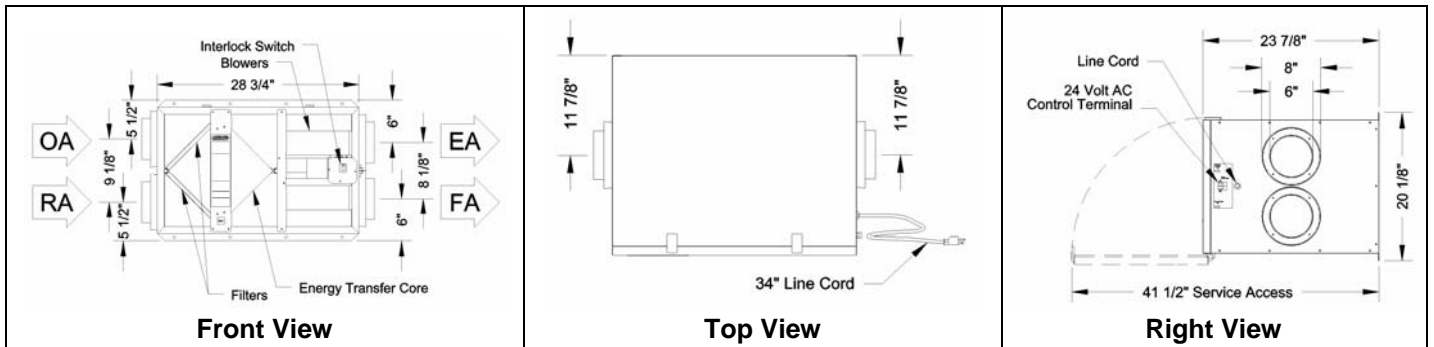

EV300

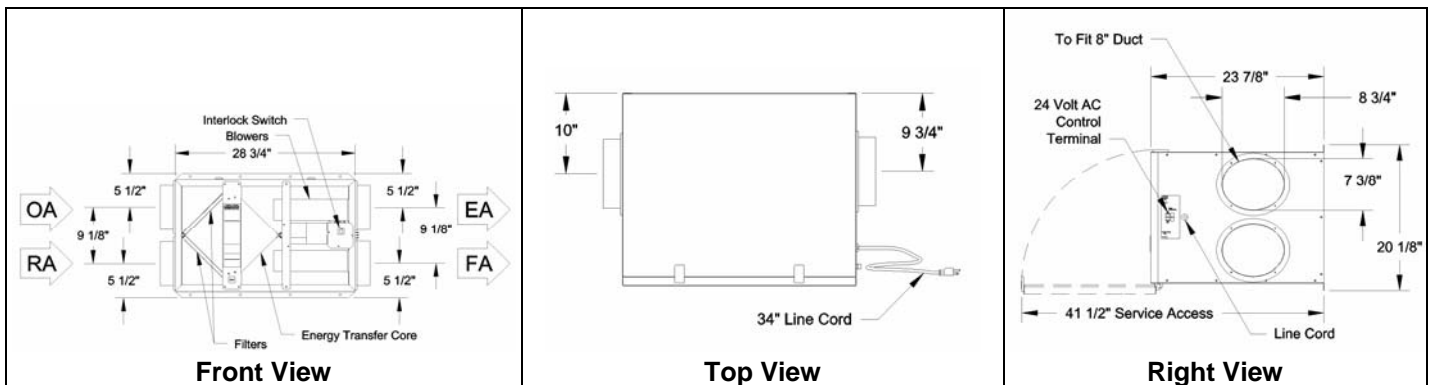

Due to continuing product development, specifications are subject to change without notice

CERTIFIED RATINGS



EV70 - Ventilation Performance							
Ext. Static Pressure		Net Supply Airflow		Gross Airflow			
				Supply		Exhaust	
Pa	in. wg	L/S	CFM	L/S	CFM	L/S	CFM
25	0.1	41	86	42	89	46	97
50	0.2	34	73	35	75	39	84
75	0.3	28	59	29	61	32	69
100	0.4	21	46	22	47	25	53

Electrical Requirements Volts 120 Amps 1.0

Exhaust Air Transfer Ratio = 4% @ 0.2 in. wg (50 PA)

EV70 - Energy Performance							
Supply Temperature		Net Airflow		Average Power Watts	Sensible Recovery Efficiency %	Apparent Sensible Effectiveness %	Net Moisture Transfer %
C°	F°	L/S	CFM				
Heating							
0°	32°	32	69	94	66	77	53
Cooling							
35°	95°	30	64	94	Total Recovery Efficiency %		42

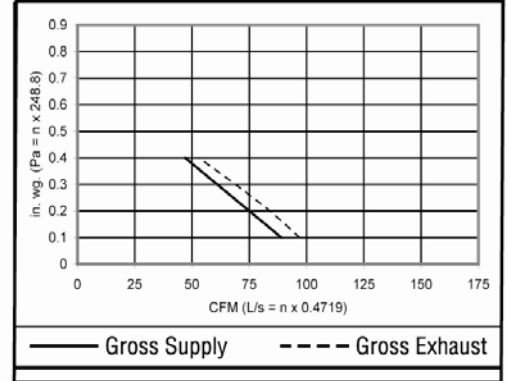

EV130 - Ventilation Performance							
Ext. Static Pressure		Net Supply Airflow		Gross Airflow			
				Supply		Exhaust	
Pa	in. wg	L/S	CFM	L/S	CFM	L/S	CFM
25	0.1	70	148	71	151	75	159
50	0.2	66	141	67	143	69	147
75	0.3	62	132	63	134	64	135
100	0.4	53	113	54	115	56	119
125	0.5	44	94	45	96	47	99
150	0.6	32	69	33	70	29	62
175	0.7	24	52	25	53	21	45

Electrical Requirements Volts 120 Amps 1.3

Exhaust Air Transfer Ratio = 2% @ 0.2 in. wg (50 PA) and 2% @ 0.4 in. wg (100 PA)

EV130 - Energy Performance							
Supply Temperature		Net Airflow		Average Power Watts	Sensible Recovery Efficiency %	Apparent Sensible Effectiveness %	Net Moisture Transfer %
C°	F°	L/S	CFM				
Heating							
0°	32°	58	124	121	72	80	55
Cooling							
35°	95°	59	126	121	Total Recovery Efficiency %		46

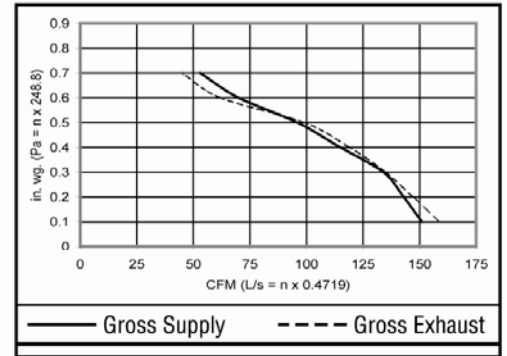

EV200 - Ventilation Performance							
Ext. Static Pressure		Net Supply Airflow		Gross Airflow			
				Supply		Exhaust	
Pa	in. wg	L/S	CFM	L/S	CFM	L/S	CFM
25	0.1	97	207	100	213	109	232
50	0.2	90	192	93	199	104	221
75	0.3	88	186	90	192	101	216
100	0.4	83	176	85	181	96	204
125	0.5	79	168	81	173	88	187
150	0.6	70	149	72	154	76	162
175	0.7	57	122	59	126	68	145

Electrical Requirements Volts 120 Amps 1.5

Exhaust Air Transfer Ratio = 3% @ 0.2 in. wg (50 PA) and 3% @ 0.4 in. wg (100 PA)

EV200 - Energy Performance							
Supply Temperature		Net Airflow		Average Power Watts	Sensible Recovery Efficiency %	Apparent Sensible Effectiveness %	Net Moisture Transfer %
C°	F°	L/S	CFM				
Heating							
0°	32°	85	181	157	78	85	62
Cooling							
35°	95°	85	180	155	Total Recovery Efficiency %		52

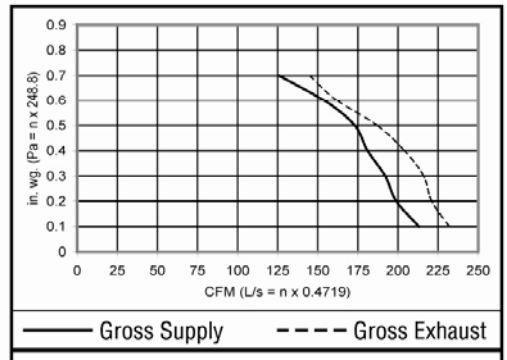

CERTIFIED RATINGS

EV300 - Ventilation Performance							
Ext. Static Pressure		Net Supply Airflow		Gross Airflow			
				Supply		Exhaust	
Pa	in. wg	L/S	CFM	L/S	CFM	L/S	CFM
100	0.4	148	315	153	325	146	311
125	0.5	141	299	145	309	138	293
150	0.6	131	279	135	287	126	268
175	0.7	119	253	123	261	111	237
200	0.8	95	202	98	209	89	189
225	0.9	77	163	79	169	69	147
250	1.0	44	93	45	96	34	72

Electrical Requirements Volts 120 Amps 3.3
 Exhaust Air Transfer Ratio = 3% @ 0.4 in. wg (50 PA)

EV300 - Energy Performance							
Supply Temperature		Net Airflow		Average Power	Sensible Recovery	Apparent Sensible	Net Moisture
C°	F°	L/S	CFM	Watts	Efficiency %	Effectiveness %	Transfer %
Heating							
0°	32°	139	295	317	70	78	51
Cooling							
35°	95°	134	285	311	Total Recovery Efficiency %		
				43			

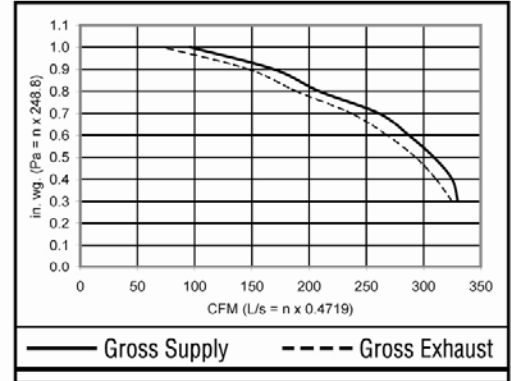

Purpose of your Energy Recovery Ventilation (ERV) System

(continued from page 12)

How much ventilation is right for you?

Different households require different rates of ventilation, depending on the pollutants found in each home. Most people use one of two methods to control the operation of their ventilation systems:

1. Provide a daily average of 0.35 Air changes per hour (ACH) for your entire home. A **proportional timer** is the primary operating control that allows you to reliably achieve this ventilation rate.

According to the American Society of Heating, Refrigeration and Air-Conditioning Engineers (ASHRAE), this ventilation rate will provide good air quality in most homes for most people. At this rate, you will be changing the air in your home over eight times per day. Most ERV systems are generally designed to provide at least this ventilation rate. Be sure to provide at least 15 CFM per person in the home. In small homes this may mean more than nine air changes per day.

Or, during the heating season in cold climates:

2. Ventilate enough in the winter to keep indoor humidity low. A **dehumidistat** is the primary operating control that allows you to maintain low winter humidity.

In the winter, water vapor inside your home mostly comes from people –breathing, showering, and cooking. When the outside air is 40°F or less, an ERV will reduce indoor humidity. This helps to prevent condensation on windows. High wintertime humidity generally means you need more ventilation to control other indoor-air pollutants, like cooking odors.

Use your judgment:

These guidelines are a starting point. As long as the pollutants you are concerned with are detectable (like water vapor or odors) your nose can be a good guide, and you may find that fewer hours of operation will be sufficient.

For households with smokers:

Smokers will need at least double the usual ventilation rate to satisfy non-smokers in the same household.

⚠ WARNING

There is no known safe level of cigarette smoke. Any ventilation system may provide noticeable improvement in spaces where cigarettes are smoked, but it cannot be expected to protect against the severe long-term health hazards of exposure to cigarette smoke.

EV70

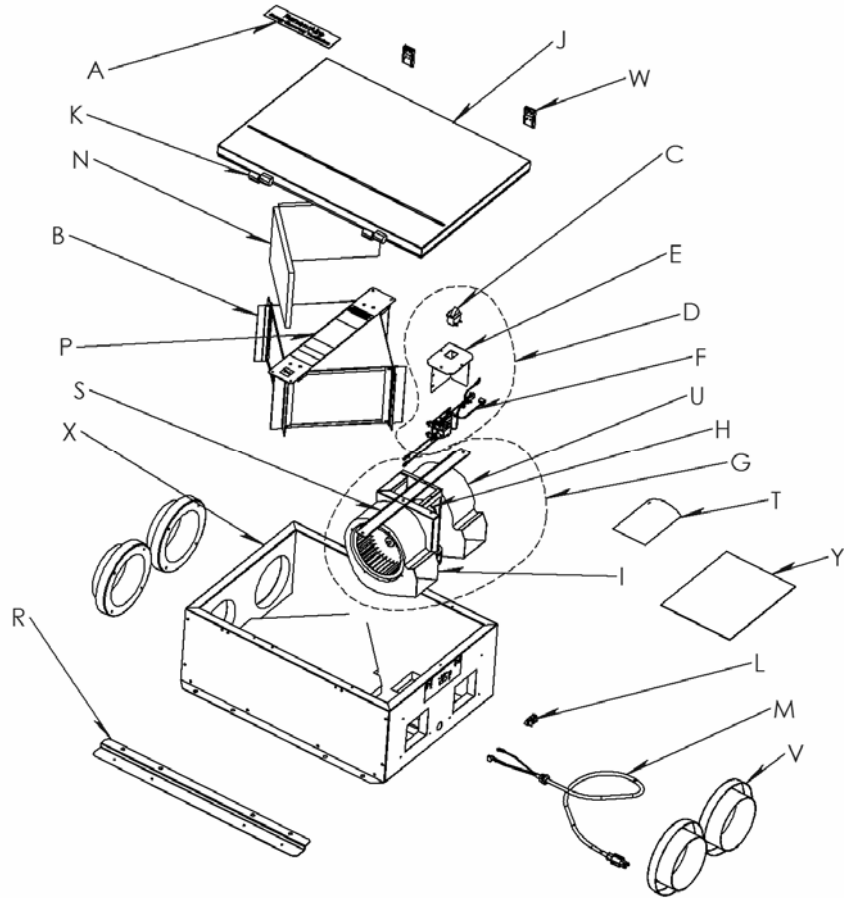

EV130

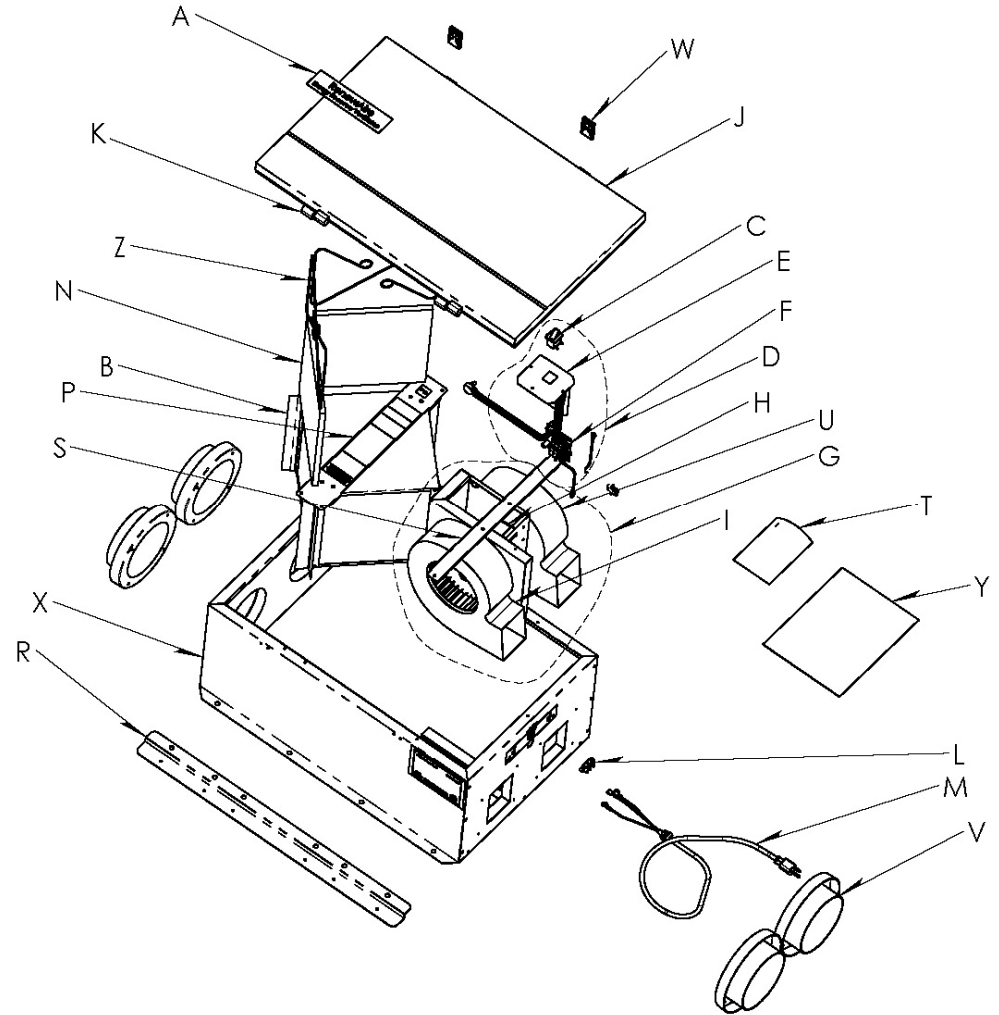

SERVICE PARTS

A. Label	H. Motor	N. Filter (set of two)	U. Blower & wheel, motor side
B. Energy Exchange Core	I. Blower & wheel, divider side	P. Core cross bar	V. Duct collar (sold singly; 4 per unit)
C. Interlock switch	J. Door assembly	Q. Core gasket kit (not shown)	W. Latch set (both parts)
D. E-box and control kit	K. Hinge set (both parts)	R. Hanging bracket kit	X. Case, insulated, without door
E. E-box	L. Terminal strip	S. Divider cross bar	Y. Literature packet
F. Control board with standoffs	M. Line cord with bushing	T. Hardware kit	Z. Filter Clip (EV130 only; sold singly; 2 per unit)
G. Blower assembly (complete)			

EV200

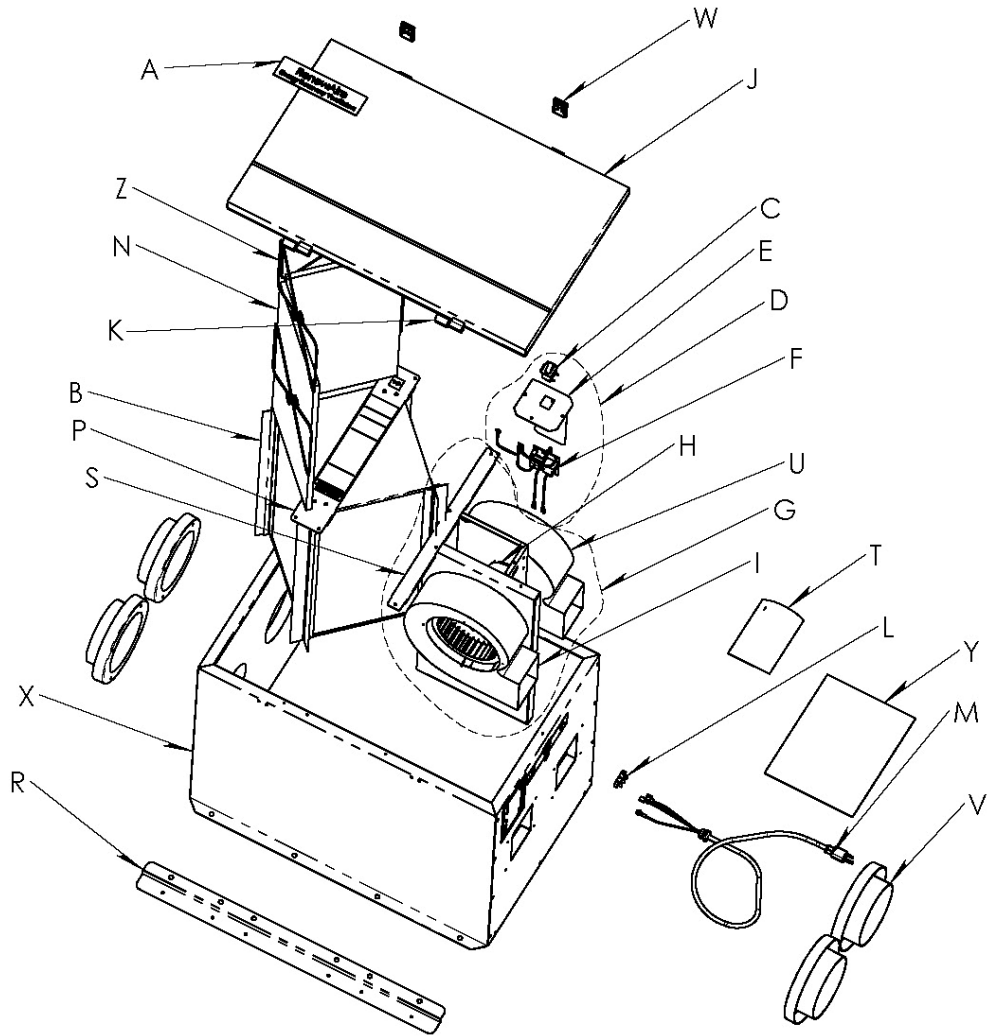

EV300

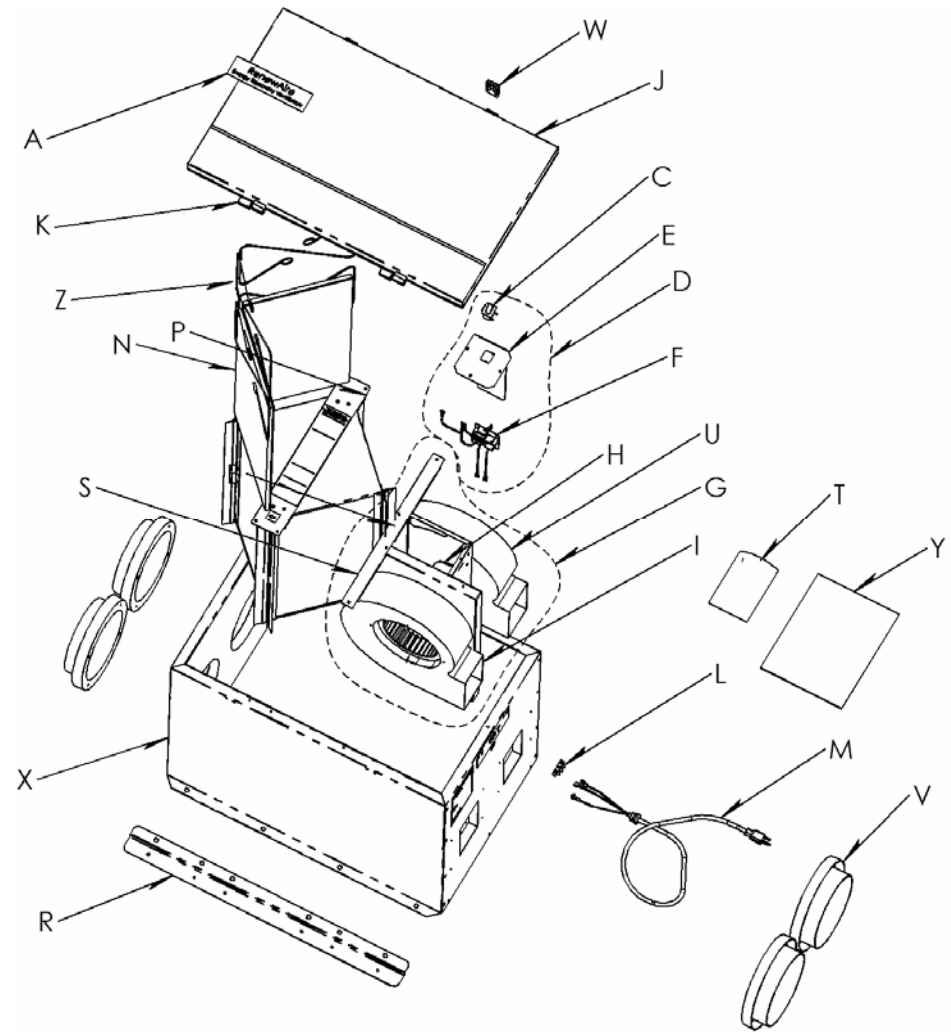

- | | | | |
|---------------------------------|---------------------------------|--|--|
| A. Label | H. Motor | P. Core cross bar | W. Latch set (both parts) |
| B. Energy Exchange Core | I. Blower & wheel, divider side | Q. Core gasket kit (not shown) | X. Case, insulated, without door |
| C. Interlock switch | J. Door assembly | R. Hanging bracket kit | Y. Literature packet |
| D. E-box and control kit | K. Hinge set (both parts) | S. Divider cross bar | Z. Filter Clip (sold singly; 4 per unit) |
| E. E-box | L. Terminal strip | T. Hardware kit | |
| F. Control board with standoffs | M. Line cord with bushing | U. Blower & wheel, motor side | |
| G. Blower assembly (complete) | N. Filter (set of two) | V. Duct collar (sold singly; 4 per unit) | |

Due to continuing product development, specifications are subject to change without notice

USE & MAINTENANCE

Maintenance Requirements

Keep your ERV performing at its best by cleaning it as described below:

⚠ WARNING

RISK OF ELECTRIC SHOCK OR INJURY.

- ◆ Before servicing or cleaning the unit, unplug the unit line cord.
- ◆ Make sure unit is not running before opening its door. Blower wheels are sharp and can cut.
- ◆ Do not disable the interlock switch: it is there for your safety.

Service filters regularly:

Service filters every three months when the unit is in regular use or as needed to keep them reasonably clean.

1. Release cam latches and carefully swing access door open. Remove the door by sliding to one side.
2. In EV130/200/300, remove filter clips.
3. Pull the filters out.
4. Vacuum with a hose attachment.
5. Re-install filters and filter clips, (see illustrations, page 7).
6. Re-install door, and fasten cam latches.

NOTE: The filters should be replaced after they have been cleaned several times. The primary contact for replacement filters for your RenewAire unit is the installing contractor. As an alternative, you may wish to produce your own filters. Please follow these instructions:

Filters may be cut from a sheet or roll of ¾" - 1" firm, spun polyester filter "hog hair" media or material, similar to the existing filter in the residential unit.

The size of each filter (2 required per unit) is as follows:

EV70	7" x 10 ½"
EV130	10 ½" x 10 ½"
EV200/EV300	10 ½" x 21 ¾"

Call your HVAC contractor or RenewAire for further information.

NOTE: Filters must be used or the face of the energy exchange core will become blocked by dust. The filters supplied in the unit are usually able to keep the energy exchange core clear for many months. Finer filters can be used but must be cleaned more often.

Clean the face of the energy exchange core yearly:

1. Remove the filters (see above).
2. Vacuum the exposed faces of the energy exchange core with a soft brush attachment.
3. After servicing the filters, re-install them (see above).
4. Vacuum out dust from the rest of the unit case.

Dust collects only on the entering faces of the energy exchange core. The interior of the energy exchange core stays clean even if the core faces are dust covered.

CAUTION

DO NOT WASH THE ENERGY EXCHANGE CORE.

Clean only as described above. The energy exchange core can be replaced but is expensive.

The blower/motor package needs no lubrication:

Vacuum clean the blower wheels at the same time you clean the face of the energy exchange core.

Purpose of an Energy Recovery Ventilation (ERV) System

Many modern homes are built air-tight for energy efficiency and comfort. The result is that natural air infiltration rates are often too low to provide acceptable indoor air quality. The solution is to use an ERV to remove gaseous pollutants such as odors, winter-time excess humidity, formaldehyde, smoke, radon, vapors from cleaning products, and other chemicals. The removal of dust and other small particles from your home is not the function of an ERV.

When should you use your ERV?

Use your ERV when windows are closed and you need to ventilate. When the outdoor air is warmer or cooler than comfortable, the ERV will allow a quieter, more secure home with the windows closed and will also save energy.

Using an ERV with air-conditioning:

An ERV works very well with air-conditioning, because its "enthalpy-transfer" energy-exchange core will reduce the amount of moisture in the outside air that is brought in. ERVs are the preferred way to ventilate while air-conditioning because it brings in less moisture than any other ventilation method.

Controlling excess humidity during cold weather:

When the ERV is first turned on at the beginning of the heating season (or when first installed), it will have to run full-time for several days to reduce indoor humidity levels. A properly set dehumidistat will do this automatically. If your control is the proportional timer type (PT or FM), it should be set to "100%" for several days whenever you have a problem with excess humidity during cold weather.

(Continued on page 9)